



# HYMAX<sup>®</sup>

(40mm - 1500mm COUPLING LONG BODY)



## PRODUCT SPECIFICATIONS

### FEATURES

- GAME-CHANGING WIDE-RANGE COUPLING, PROVEN IN MILLIONS OF INSTALLATIONS WORLDWIDE
- SUITABLE FOR ALL PIPES - DUCTILE IRON, CAST IRON, STEEL, PE, PVC, AC, GRP
- PATENTED PROGRESSIVE PRESSURE-ASSISTED GASKET WITH 2-STAGE SEALING
- LONG BODY FOR EXTRA SIZE FLEXIBILITY
- LIGHTWEIGHT CONSTRUCTION ENABLES FAST AND EASY INSTALLATION
- ALLOWS 4° DYNAMIC DEFLECTION ON EACH END, REDUCING FUTURE PIPE DAMAGE
- ONE PRODUCT CAN CONNECT PIPES OF TWO DIFFERENT MATERIALS

### SPECIFICATIONS (\*)

#### STANDARDS

ALL PRODUCTS MEET OR EXCEED STANDARDS NSF-61 AND NSF-372.

#### SIZE

AVAILABLE IN NOMINAL DIAMETER SIZES 40mm - 1500mm.

#### MATERIALS

##### END RINGS

40mm - 300mm: S235JR GRADE STEEL, IN ACCORDANCE WITH EN 10025-2 (DIN 17100).  
350mm - 400mm: S235JR GRADE STEEL, IN ACCORDANCE WITH EN 10025-2 (DIN 17100).  
(OR DUCTILE IRON CASTING ASTM A536 GRADE 60-40-18).  
450mm - 1500mm: S235JR GRADE STEEL, IN ACCORDANCE WITH EN 10025-2 (DIN 17100).

##### CENTER RING

40mm - 300mm: P235 GRADE STEEL, IN ACCORDANCE WITH EN 10217-1.  
350mm - 1500mm: S235JR GRADE STEEL, IN ACCORDANCE WITH EN 10025-2 (DIN 17100).

##### GASKET

EPDM COMPOUNDED FOR WATER AND SEWERAGE. MEETS INTERNATIONAL STANDARDS FOR CONTACT WITH DRINKING WATER: NSF-61, KTW, W270, XP P 41-250, AND BS 6920. MEETS DIN EN 681-1 FOR WATER AND DRAINAGE APPLICATIONS.

##### BRIDGE

AISI 304 STAINLESS STEEL.

##### SPHERICAL SPACERS

AISI 304L STAINLESS STEEL.

##### COATING

100% FUSION BONDED EPOXY FOR ENHANCED CORROSION PROTECTION. AVERAGE THICKNESS 250 MICRON. MEETS NSF-61, BS 6920, W270, ONORM B 5014-1, XP P 41-250, AS/NZS 4020, AND UBA-COATINGS GUIDELINE.

##### NUTS AND BOLTS

AISI 304 STAINLESS STEEL. ROLLED THREAD AND ANTI-GALLING COATING.

\* For details about Made to Order (MTO) products please contact your KRAUSZ distributor.

## PRODUCT PERFORMANCE (\*)

<b>WORKING TEMPERATURE</b>	<b>EPDM GASKET</b> CONTINUOUS OPERATION   -30°C UP TO +85°C SHORT TIME OPERATION   -30°C UP TO +100°C		<b>EPOXY COATING</b> ABOVE GROUND APPLICATIONS   UP TO +50°C BELOW GROUND APPLICATIONS   UP TO +65°C	
<b>DYNAMIC DEFLECTION</b>	<b>UP TO 4° PER SIDE</b>			
<b>MIN. PIPE INSERTION</b>	<b>40mm – 300mm</b> 55mm	<b>350mm – 600mm</b> 140mm	<b>650mm – 1500mm</b> 150mm	
<b>MAXIMUM OFFSET FOR MISALIGNED PIPES</b>	<b>40mm – 80mm</b> 10mm	<b>100mm – 1500mm</b> 13mm		
<b>MAXIMUM OUT OF ROUNDNESS</b>	<b>40mm</b> 2mm	<b>50mm – 80mm</b> 5mm	<b>100mm – 300mm</b> 8mm	<b>350mm – 1500mm</b> 13mm
<b>WORKING PRESSURE</b>	<b>40mm – 600mm</b> 16 BAR	<b>650mm – 1500mm</b> CONTACT KRAUSZ DISTRIBUTOR FOR DETAILS		
<b>RATED PRESSURE</b>	<b>1.5 X WORKING PRESSURE</b>			
<b>VACUUM TEST</b>	<b>0.8 BAR</b>			

\* See Submittal Drawings For Details.

## PRODUCT TABLES

### HYMAX Long Body Coupling 40-300

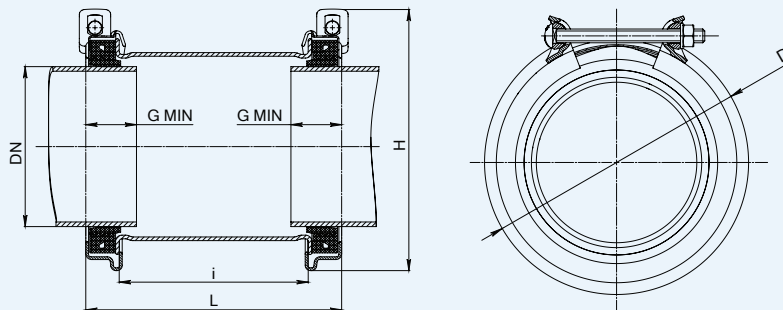

### HYMAX LONG BODY NOMINAL SIZES 40-300mm

Krausz Part Number	DN (mm)	Overall Range (mm)	Before removal of inner layer (mm)	After removal of inner layer (mm)	D (mm)	H (mm)	i (mm)	L (mm)	Bolts Qty. -Size	Torque (Nm)	Approx. Weight (kg)
862-825-0041-16	40	41-54	41-50.5	50-54	Ø100	130	192	250	2 -M12	45	3.3
862-825-0054-16	50	54-77	54-66	65-77	Ø133	165	192	267	2 -M12	60	3.7
862-825-0088-16	80	88-108	88-99	98-108	Ø170	200	292	367	2 -M12	60	6.4
862-825-0108-16C	100	108-143	108-126	125-143	Ø220	250	292	365	2 -M14	80	9.5
862-825-0130-16	125	130-162	130-146	145-162	Ø240	270	402	475	2 -M14	80	12.5
862-825-0158-16	150	158-190	158-174	173-190	Ø270	295	402	475	2 -M14	80	14.0
862-825-0163-16	150 o.s.	163-195	163-179	178-195	Ø273	298	402	475	2 -M14	80	14.7
862-825-0190-16	175	190-222	190-206	205-222	Ø298	325	402	475	2 -M14	80	16.4
862-825-0217-16	200	217-250	217-233	232-250	Ø328	355	402	475	2 -M14	80	19.1
862-825-0272-16	250	272-305	272-289	288-305	Ø382	408	402	475	2 -M14	80	22.7
862-825-0278-16	250 o.s.	278-311	278-295	294-311	Ø388	415	402	475	2 -M14	80	24.1
862-825-0315-16	300	315-347	315-331	330-347	Ø422	445	402	475	2 -M14	80	24.5
862-825-0334-16	300 o.s.	334-366	334-350	349-366	Ø440	465	402	475	2 -M14	80	25.4

## PRODUCT TABLES

### HYMAX Long Body Coupling 350-600

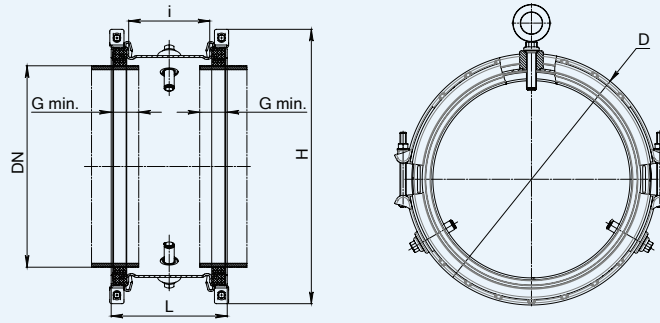

### HYMAX LONG BODY NOMINAL SIZES 350-600mm

Krausz Part Number	DN (mm)	Overall Range (mm)	Before removal of inner layer (mm)	After removal of inner layer (mm)	D (mm)	H (mm)	i (mm)	L (mm)	Bolts Qty. -Size	Torque (Nm)	Approx. Weight (kg)
862-825-0378-16P	350	378-434	378-408	406-434	Ø534	600	370	460	4 -M16	200	48.5
862-825-0434-16P	400	434-488	434-462	460-488	Ø588	655	370	460	4 -M16	200	56.0
862-825-0488-16P	450	488-542	488-516	514-542	Ø642	705	370	460	4 -M16	200	60.0
862-825-0540-16P	500	540-594	540-568	566-594	Ø694	760	370	460	4 -M16	200	64.0
862-825-0606-16P	600	606-660	606-634	632-660	Ø760	825	370	460	4 -M16	200	72.0
862-825-0624-16P	600 o.s.	624-678	624-652	650-678	Ø778	845	370	460	4 -M16	200	74.0

### HYMAX LONG BODY NOMINAL SIZES 650-1500mm (\*)

DN - 650 up to 1500 mm with range of 54 mm	DN (mm)	Bolts Qty. -Size	Torque (Nm)	Working Pressure (bar)	Rated Pressure (bar)
	650-900	4-1"NCx350	300	12	18
	900-1000	4-1"NCx350	400	12	18
	1000-1300	4-1"NCx350	400	10	15
	1300-1350	4-1"NCx350	450	10	15
	1350-1500	4-1"NCx350	450	8	12

\* Contact your KRAUSZ distributor for more details.