



HYMAX® GRIP

(40mm - 300mm) Currently available in sizes 40mm-150mm

PRODUCT SPECIFICATIONS

FEATURES

- JOINS AND RESTRAINS A WIDE RANGE OF PIPING TYPES AND DIAMETERS
- UNIQUE RADIAL GRIPPING SYSTEM PREVENTS PIPE MOTION
- UNIVERSAL GRIPPING TEETH FIT METAL AND PLASTIC PIPES
- READY TO USE, STAB-FIT DESIGN
- ALLOWS 4° DYNAMIC DEFLECTION PER END, REDUCING FUTURE DAMAGE
- DURABLE DUCTILE IRON BODY
- PATENTED PROGRESSIVE PRESSURE-ASSISTED GASKET WITH 2-STAGE SEALING

SPECIFICATIONS (*)

STANDARDS

ALL PRODUCTS MEET OR EXCEED STANDARDS NSF-61 AND NSF-372.

SIZE

AVAILABLE IN NOMINAL DIAMETER SIZES 40mm – 300mm.

RANGES

26mm – 28mm: NOMINAL DIAMETERS 40mm – 100mm.
32mm: NOMINAL DIAMETERS 125mm – 175mm.
50mm: NOMINAL DIAMETERS 175mm – 300mm.

MATERIALS

END RINGS

40mm – 80mm: CAST STEEL ASTM A216 WCB.
100mm – 300mm: DUCTILE IRON CASTING ASTM A536 GRADE 60-40-18.

CENTER RING

40mm – 300mm: DUCTILE IRON CASTING ASTM A536 GRADE 65-45-12.
PRODUCT SIZES 100mm – 300mm WITH HANDLE.

GASKET

EPDM COMPOUNDED FOR WATER AND SEWERAGE, MEETS INTERNATIONAL STANDARDS FOR CONTACT WITH DRINKING WATER: NSF-61, KTW, W270, XP P 41-250, AND BS 6920. MEETS DIN EN 681-1 FOR WATER AND DRAINAGE APPLICATIONS.

GRIP CHAIN

SIZE	40mm - 80mm	100mm - 175mm	175mm - 300mm
MATERIAL	AISI-440C	AISI-420 2B	AISI-420

BRIDGE

AISI 304 STAINLESS STEEL.

SPHERICAL SPACERS

AISI 304L STAINLESS STEEL.

COATING

100% FUSION BONDED EPOXY FOR ENHANCED CORROSION PROTECTION. AVERAGE THICKNESS 250 MICRON. MEETS NSF-61, BS 6920, W270, ONORM B 5014-1, XP P 41-250, AS/NZS 4020, AND UBA-COATINGS GUIDELINE.

NUTS AND BOLTS

AISI 304 STAINLESS STEEL. ROLLED THREAD AND ANTI-GALLING COATING.

* For details about Made to Order (MTO) products please contact your KRAUSZ distributor.

PRODUCT PERFORMANCE (*)

WORKING TEMPERATURE	EPDM GASKET CONTINUOUS OPERATION -30°C UP TO +85°C SHORT TIME OPERATION -30°C UP TO +100°C	EPOXY COATING ABOVE GROUND APPLICATIONS UP TO +50°C BELOW GROUND APPLICATIONS UP TO +65°C
DYNAMIC DEFLECTION	UP TO 4° PER SIDE	
MIN. PIPE INSERTION	RANGE ≤ 32mm 50mm MIN. PIPE INSERTION 95mm 125mm	
MAXIMUM OFFSET FOR MISALIGNED PIPES	40mm – 300mm 6mm	
MAXIMUM OUT OF ROUNDNESS	NOMINAL DIAMETER ≤ 80mm ≥ 100mm OUT OF ROUNDNESS 3mm 4mm	
WORKING PRESSURE	16 BAR	
RATED PRESSURE	1.5 X WORKING PRESSURE	
VACUUM TEST	0.8 BAR	

* See Submittal Drawings For Details.

PRODUCT TABLES

HYMAX GRIP 40-80

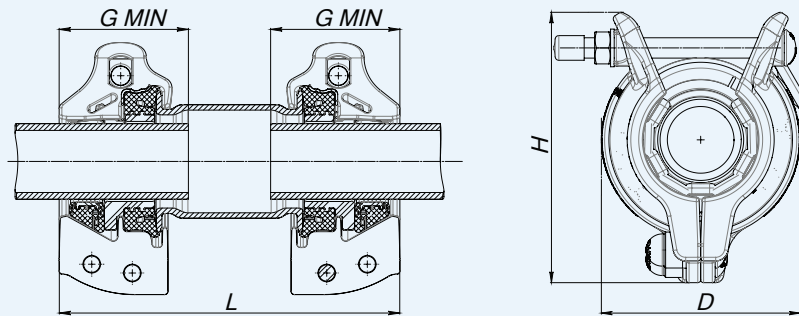

HYMAX GRIP NOMINAL SIZES 40-80mm

Krausz Part Number	DN (mm)	Overall Range (mm)	Before removal of inner layer (mm)	After removal of inner layer (mm)	L (mm)	H (mm)	D (mm)	Bolts Qty. -Size	Torque (Nm)	Approx. Weight (kg)
890-825-015039-16	40/50	39-67	39-56	55-67	254	190	136	2-M14	70	7.01
890-825-025059-16	65	59-87	59-76	75-87	254	205	157	2-M14	70	9.19
890-825-030080-16	80	80-106	80-95	94-106	303	230	176	2-M14	70	11.58

PRODUCT TABLES

HYMAX GRIP 100-300

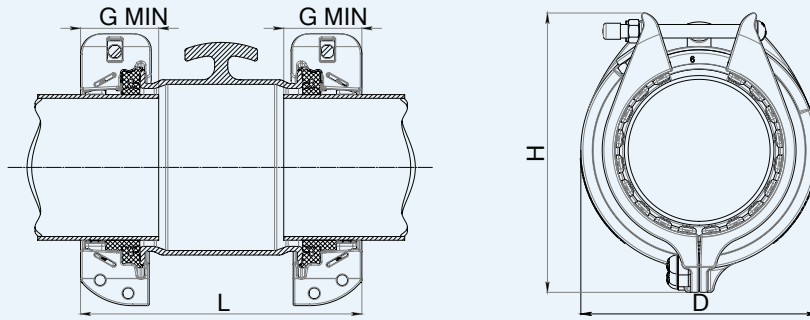

HYMAX GRIP NOMINAL SIZES 100-175mm CURRENTLY AVAILABLE UP TO DN 150mm

Krausz Part Number	DN (mm)	Overall Range (mm)	Before removal of inner layer (mm)	After removal of inner layer (mm)	L (mm)	H (mm)	D (mm)	Bolts Qty. -Size	Torque (Nm)	Approx. Weight (kg)
890-825-04104-16	100	104-130	104-118	117-130	301	249	199	2-M16	100	12
890-825-05130-16	125	130-162	130-146	145-162	342	299	253	2-M16	110	20.4
890-825-06158-16	150	158-190	158-174	173-190	342	330	280	2-M16	110	22.8
890-825-07198-16	175	198-230	198-214	213-230	342	375	324	2-M16	110	27.8

HYMAX GRIP NOMINAL SIZES 175-300mm | coming soon

Krausz Part Number	DN (mm)	Overall Range (mm)	Before removal of inner layer (mm)	After removal of inner layer (mm)	L (mm)	H (mm)	D (mm)	Bolts Qty. -Size	Torque (Nm)	Approx. Weight (kg)
890-825-07190-16	175	190-240	190-215	214-240	403	398	355	4-M16	110	44
890-825-08214-16	200	214-264	214-239	238-264	403	424	380	4-M16	120	47.5
890-825-10266-16	250	266-316	266-291	290-316	405	480	433	4-M16	120	57
890-825-12312-16	300	312-362	312-337	336-362	405	525	479	4-M16	160	63.8