



HYMAX® FLANGE ADAPTER

(80mm - 300mm) Currently available in sizes 80mm-150mm

PRODUCT SPECIFICATIONS

FEATURES

- JOINS AND RESTRAINS A WIDE RANGE OF PIPING TYPES AND DIAMETERS WITH FLANGED DEVICES
- UNIQUE RADIAL GRIPPING SYSTEM PREVENTS PIPE MOTION
- UNIVERSAL GRIPPING TEETH FIT METAL AND PLASTIC PIPES
- READY TO USE, STAB-FIT DESIGN
- ALLOWS 4° DYNAMIC DEFLECTION, REDUCING FUTURE DAMAGE
- DURABLE DUCTILE IRON BODY
- PATENTED PROGRESSIVE PRESSURE-ASSISTED GASKET WITH 2-STAGE SEALING

SPECIFICATIONS (*)

STANDARDS

ALL PRODUCTS MEET OR EXCEED STANDARDS NSF-61 AND NSF-372.

SIZE

AVAILABLE IN NOMINAL DIAMETER SIZES 80mm – 300mm.

RANGES

26mm: NOMINAL DIAMETERS 80mm – 100mm.
32mm: NOMINAL DIAMETERS 125mm – 175mm.
50mm: NOMINAL DIAMETERS 175mm – 300mm.

MATERIALS

FLANGED BODY

80mm – 300mm: DUCTILE IRON CASTING ASTM A536 GRADE 65-45-12.

FLANGES

PN-10/16: 80mm – 300mm

END RINGS

80mm: CAST STEEL ASTM A216 WCB.
100mm – 300mm: DUCTILE IRON CASTING ASTM A536 GRADE 60-40-18.

GASKET

EPDM COMPOUNDED FOR WATER AND SEWERAGE, MEETS INTERNATIONAL STANDARDS FOR CONTACT WITH DRINKING WATER: NSF-61, KTW, W270, XP P 41-250, AND BS 6920. MEETS DIN EN 681-1 FOR WATER AND DRAINAGE APPLICATIONS.

GRIP CHAIN

| | | | |
|----------|-----------|---------------|---------------|
| SIZE | 80mm | 100mm - 175mm | 175mm - 300mm |
| MATERIAL | AISI-440C | AISI-420 2B | AISI-420 |

BRIDGE

AISI 304 STAINLESS STEEL.

SPHERICAL SPACERS

AISI 304L STAINLESS STEEL.

COATING

100% FUSION BONDED EPOXY FOR ENHANCED CORROSION PROTECTION. AVERAGE THICKNESS 250 MICRON. MEETS NSF-61, BS 6920, W270, ONORM B 5014-1, XP P 41-250, AS/NZS 4020, AND UBA-COATINGS GUIDELINE.

NUTS AND BOLTS

AISI 304 STAINLESS STEEL. ROLLED THREAD AND ANTI-GALLING COATING.

* For details about Made to Order (MTO) products please contact your KRAUSZ distributor.

PRODUCT PERFORMANCE (*)

| | | |
|--|---|--|
| WORKING TEMPERATURE | EPDM GASKET CONTINUOUS OPERATION -30°C UP TO +85°C SHORT TIME OPERATION -30°C UP TO +100°C | EPOXY COATING ABOVE GROUND APPLICATIONS UP TO +50°C BELOW GROUND APPLICATIONS UP TO +65°C |
| DYNAMIC DEFLECTION | UP TO 4° | |
| MIN. PIPE INSERTION | RANGE ≤ 32mm 50mm MIN. PIPE INSERTION 95mm 125mm | |
| MAXIMUM OFFSET FOR MISALIGNED PIPES | 80mm – 300mm 3 mm | |
| MAXIMUM OUT OF ROUNDNESS | NOMINAL DIAMETER ≤ 80mm ≥ 100mm OUT OF ROUNDNESS 3mm 4mm | |
| WORKING PRESSURE | 80mm – 300mm 16 BAR | |
| RATED PRESSURE | 1.5 X WORKING PRESSURE | |
| VACUUM TEST | 0.8 BAR | |

* See Submittal Drawings For Details.

PRODUCT TABLES

HYMAX GRIP FLANGE ADAPTOR 80-175

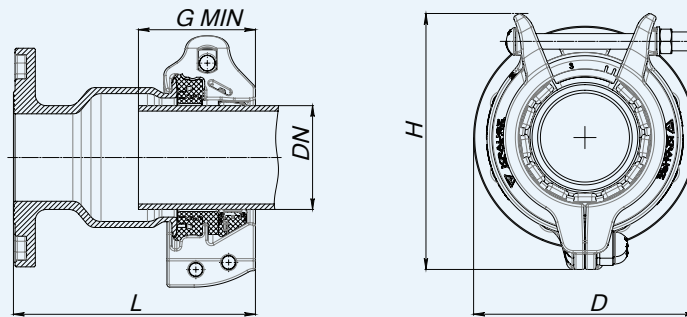

HYMAX GRIP FLANGE ADAPTOR NOMINAL SIZES 80-175mm CURRENTLY AVAILABLE UP TO DN 150mm

| Krausz Part Number | DN (mm) | Overall Range (mm) | Before removal of inner layer (mm) | After removal of inner layer (mm) | L (mm) | H (mm) | D (mm) | Bolts Qty. -Size | Torque (Nm) | Approx. Weight (kg) |
|--------------------|---------|--------------------|------------------------------------|-----------------------------------|--------|--------|--------|------------------|-------------|---------------------|
| 130-825-030080-16 | 80 | 80-106 | 80-95 | 94-106 | 222 | 230 | 200 | 1-M14 | 70 | 9.03 |
| 130-825-04104-16 | 100 | 104-130 | 104-119 | 118-130 | 222 | 249 | 229 | 1-M16 | 100 | 10.96 |
| 130-825-05130-16 | 125 | 130-162 | 130-146 | 145-162 | 251 | 294 | 254 | 1-M16 | 110 | 15.33 |
| 130-825-06158-16 | 150 | 158-190 | 158-174 | 173-190 | 260 | 325 | 285 | 1-M16 | 110 | 18.19 |
| 130-825-07198-16 | 175 | 198-230 | 198-214 | 213-230 | 283 | 369 | 315 | 1-M16 | 110 | 23.84 |

PRODUCT TABLES

HYMAX GRIP FLANGE ADAPTOR 175-300

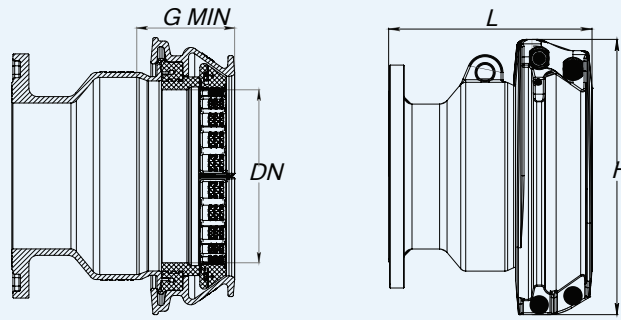

HYMAX GRIP FLANGE ADAPTOR NOMINAL SIZES 175-300mm | coming soon

| Krausz Part Number | DN (mm) | Overall Range (mm) | Before removal of inner layer (mm) | After removal of inner layer (mm) | L (mm) | H (mm) | D (mm) | Bolts Qty. -Size | Torque (Nm) | Approx. Weight (kg) |
|--------------------|---------|--------------------|------------------------------------|-----------------------------------|--------|--------|--------|------------------|-------------|---------------------|
| 130-825-07190-16 | 175 | 190-240 | 190-215 | 214-240 | 312 | 398 | 355 | 2-M16 | 110 | 34.19 |
| 130-825-08214-16 | 200 | 214-264 | 214-239 | 238-264 | 313 | 405 | 380 | 2-M16 | 120 | 36.95 |
| 130-825-10266-16 | 250 | 266-316 | 266-291 | 290-316 | 327 | 461 | 433 | 2-M16 | 120 | 48.33 |
| 130-825-12312-16 | 300 | 312-362 | 312-337 | 336-362 | 329 | 505 | 479 | 2-M16 | 160 | 56.7 |