



HYMAX® FLANGE ADAPTOR*

(40mm - 1500mm)

PRODUCT SPECIFICATIONS

FEATURES

- USING THE GAME-CHANGING HYMAX TECHNOLOGY, PROVEN IN MILLIONS OF INSTALLATIONS WORLDWIDE
- SUITABLE FOR ALL TYPES OF PIPES - DUCTILE IRON, CAST IRON, STEEL, PE, PVC, AC, GRP
- PATENTED PROGRESSIVE PRESSURE-ASSISTED GASKET WITH 2-STAGE SEALING
- LIGHTWEIGHT CONSTRUCTION ENABLES FAST AND EASY INSTALLATION
- ALLOWS 4° DYNAMIC DEFLECTION, REDUCING FUTURE PIPE DAMAGE

SPECIFICATIONS (**)

STANDARDS

ALL PRODUCTS MEET OR EXCEED STANDARDS NSF-61 AND NSF-372.
 PRODUCTS UP TO DN 300 WERE APPROVED BY 3RD PARTY ILAC LAB ACCORDING TO EN 14525.

SIZE

AVAILABLE IN NOMINAL DIAMETER SIZES 40mm - 600mm (STANDARD).
 650mm - 1500mm are MTO (MADE TO ORDER). CONTACT KRAUSZ DISTRIBUTOR FOR DETAILS.

MATERIALS

END RINGS

40mm - 300mm: S235JR GRADE STEEL, IN ACCORDANCE WITH EN 10025-2 (DIN 17100).
 350mm - 400mm: S235JR GRADE STEEL, IN ACCORDANCE WITH EN 10025-2 (DIN 17100)
 (OR DUCTILE IRON CASTING ASTM A536 GRADE 60-40-18).
 450mm - 1500mm: S235JR GRADE STEEL, IN ACCORDANCE WITH EN 10025-2 (DIN 17100).

FLANGED BODY

40mm - 300mm: P235 GRADE STEEL, IN ACCORDANCE WITH EN 10217-1.
 350mm - 1500mm: S235JR GRADE STEEL, IN ACCORDANCE WITH EN 10025-2 (DIN 17100).

FLANGE

PN-10/16: 200mm - 600mm (***)
 PN-16: 40mm - 1500mm (****)
 PN-10: 40mm - 1500mm (****)
 BSTD: 50mm - 1500mm

GASKET

EPDM COMPOUNDED FOR WATER AND SEWERAGE. MEETS INTERNATIONAL STANDARDS FOR CONTACT WITH DRINKING WATER: NSF-61, KTW-UBA Elastomer guideline, W270, XP P 41-250, AS/NZS 4020, AND BS 6920. MEETS DIN EN 681-1 FOR WATER AND DRAINAGE APPLICATIONS.

BRIDGE

AISI 304 STAINLESS STEEL.

SPHERICAL SPACERS

AISI 304L STAINLESS STEEL.

COATING

100% FUSION BONDED EPOXY FOR ENHANCED CORROSION PROTECTION. AVERAGE THICKNESS 250 MICRON. MEETS NSF-61, BS 6920, W270, ONORM B 5014-1, XP P 41-250, AS/NZS 4020, AND UBA-COATINGS GUIDELINE.

NUTS AND BOLTS

AISI 304 STAINLESS STEEL. ROLLED THREAD AND ANTI-GALLING COATING.

* The product is protected by various patents registered in various countries.

** For details about Made to Order (MTO) products please contact your KRAUSZ distributor.

*** Flange pattern is compatible to PN-10 and PN-16.

**** For sizes 40mm - 175mm, the flange patterns of PN-10 and PN-16 are identical

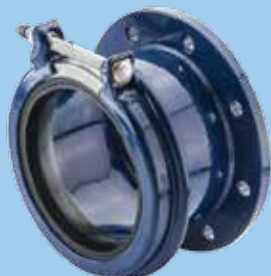

HYMAX® FLANGE ADAPTOR

(40mm - 1500mm)

PRODUCT SPECIFICATIONS

PRODUCT PERFORMANCE

WORKING TEMPERATURE

EPDM GASKET

CONTINUOUS OPERATION | -30°C UP TO +85°C
 SHORT TIME OPERATION | -30°C UP TO +100°C

EPOXY COATING

ABOVE GROUND APPLICATIONS | UP TO +50°C
 BELOW GROUND APPLICATIONS | UP TO +65°C

DYNAMIC DEFLECTION

UP TO 4°

MIN. PIPE INSERTION

40mm – 300mm
 55mm

350mm – 1500mm
 100mm

MAXIMUM OFFSET FOR MISALIGNED PIPES

40mm – 80mm
 5mm

100mm – 1500mm
 6mm

MAXIMUM OUT OF ROUNDNESS

40mm
 2mm

50mm – 80mm
 5mm

100mm – 300mm
 8mm

350mm – 1500mm
 13mm

WORKING PRESSURE

FLANGE PN-10/16		FLANGE PN-16		FLANGE PN-10		BSTD	
200mm - 600mm	16 BAR	40mm - 600mm	16 BAR	40mm - 1350mm	10 BAR	50mm - 600mm	12.5 BAR
		650mm - 1000mm	12 BAR	1350mm - 1500mm	8 BAR	650mm - 1000mm	12 BAR
		1000mm - 1350mm	10 BAR			1000mm - 1350mm	10 BAR
		1350mm - 1500mm	8 BAR			1350mm - 1500mm	8 BAR

RATED PRESSURE

1.5 X WORKING PRESSURE

VACUUM TEST

0.8 BAR

PRODUCT TABLES

HYMAX FLANGE ADAPTOR 40-300

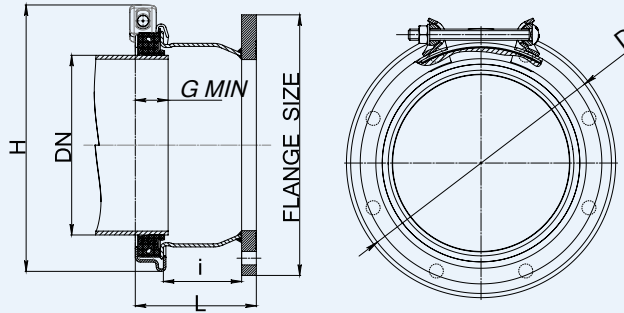

HYMAX FLANGE ADAPTOR PN-10 NOMINAL SIZES 200-300mm (※)

Krausz Part Number	DN (mm)	Flange PN-10 (mm)	Overall Range (mm)	Before removal of inner layer (mm)	After removal of inner layer (mm)	D (mm)	H (mm)	i (mm)	L (mm)	Bolts Qty. -Size	Torque (Nm)	Approx. Weight (kg)
871-825-08019010	175	200	190-222	190-206	205-222	298	325	101	160	1 -M14	80	15.3
871-825-08021710	200	200	217-250	217-233	232-250	328	355	101	161	1 -M14	80	15.8
871-825-10027210	250	250	272-305	272-289	288-305	382	408	101	163	1 -M14	80	16.5
871-825-10027810	250 o.s.	250	278-311	278-295	294-311	388	415	101	163	1 -M14	80	16.6
871-825-12031510	300	300	315-347	315-331	330-347	422	445	101	165	1 -M14	80	18.8
871-825-12033410	300 o.s.	300	334-366	334-350	349-366	440	465	101	165	1-M14	80	19.3
871-825-14033410	300 o.s.	350	334-366	334-350	349-366	440	465	101	165	1-M14	80	35.0

※For sizes 40mm - 175mm, PN-10 and PN-16 have identical flange patterns. See p. 4 for product data.

HYMAX FLANGE ADAPTOR 350-600

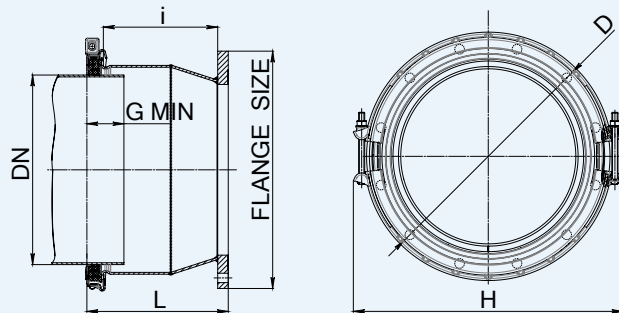

HYMAX FLANGE ADAPTOR PN-10 NOMINAL SIZES 350-600mm

Krausz Part Number	DN (mm)	Flange PN-10 (mm)	Overall Range (mm)	Before removal of inner layer (mm)	After removal of inner layer (mm)	D (mm)	H (mm)	i (mm)	L (mm)	Bolts Qty. -Size	Torque (Nm)	Approx. Weight (kg)
871-825-14037510	350	350	375-431	375-405	403-431	534	600	307	387	2 -M16	200	50.8
871-825-14037810			378-434	378-408	406-434	534	600	307	387	2 -M16	200	50.8
871-825-16043410	400	400	434-488	434-462	460-488	588	655	307	389	2 -M16	200	59.5
871-825-18048810	450	450	488-542	488-516	514-542	642	705	307	392	2 -M16	200	72.7
871-825-20054010	500	500	540-594	540-568	566-594	694	760	307	395	2 -M16	200	82.0
871-825-24060610	600	600	606-660	606-634	632-660	760	825	307	399	2 -M16	200	96.5
871-825-24062410	600 o.s.	600	624-678	624-652	650-678	778	845	307	399	2 -M16	200	102.0

PRODUCT TABLES

HYMAX FLANGE ADAPTOR PN-16 NOMINAL SIZES 40-300mm

Krausz Part Number	DN (mm)	Flange PN-16 (mm)	Overall Range (mm)	Before removal of inner layer (mm)	After removal of inner layer (mm)	D (mm)	H (mm)	i (mm)	L (mm)	Bolts Qty. -Size	Torque (Nm)	Approx. Weight (kg)
879-825-01004116	40	40	41-54	41-50.5	50-54	100	130	103	150	1 -M12	45	3.5
879-825-02005416	50	50	54-77	54-66	65-77	133	165	95	149	1 -M12	60	4.5
879-825-03008816	80	80	88-108	88-99	98-108	170	200	73	129	1 -M12	60	5.4
879-825-03010816	100	80	108-143	108-126	125-143	220	250	158	214	1 -M14	80	8.4
879-825-04010816	100	100	108-143	108-126	125-143	220	250	73	130	1 -M14	80	8.2
879-825-05013016	125	125	130-162	130-146	145-162	240	270	101	159	1 -M14	80	9.7
879-825-06013016	125	150	130-162	130-146	145-162	240	270	101	159	1 -M14	80	10.8
879-825-06015816	150	150	158-190	158-174	173-190	270	295	101	161	1 -M14	80	11.2
879-825-06016316	150 o.s.	150	163-195	163-179	178-195	273	298	101	161	1 -M14	80	11.2
879-825-07019016	175	175	190-222	190-206	205-222	298	325	101	161	1 -M14	80	13.2
879-825-08019016	175	200	190-222	190-206	205-222	298	325	101	163	1 -M14	80	14.0
879-825-08021716	200	200	217-250	217-233	232-250	328	355	101	163	1 -M14	80	14.5
879-825-10027216	250	250	272-305	272-289	288-305	382	408	101	165	1 -M14	80	18.3
879-825-10027816	250 o.s.	250	278-311	278-295	294-311	388	415	101	165	1 -M14	80	18.4
879-825-12031516	300	300	315-347	315-331	330-347	422	445	101	169	1 -M14	80	20.8
879-825-12033416	300 o.s.	300	334-366	334-350	349-366	440	465	101	169	1 -M14	80	21.3
879-825-14033416	300 o.s.	350	334-366	334-350	349-366	440	465	101	172	1 -M14	80	35.0

* See drawing on p. 3

HYMAX FLANGE ADAPTOR PN-16 NOMINAL SIZES 350-600mm

Krausz Part Number	DN (mm)	Flange PN-16 (mm)	Overall Range (mm)	Before removal of inner layer (mm)	After removal of inner layer (mm)	D (mm)	H (mm)	i (mm)	L (mm)	Bolts Qty. -Size	Torque (Nm)	Approx. Weight (kg)
879-825-14037516	350	350	375-431	375-405	403-431	534	600	307	392	2 -M16	200	57.3
879-825-14037816			378-434	378-408	406-434	534	600	307	392	2 -M16	200	57.3
879-825-16043416	400	400	434-488	434-462	460-488	588	655	307	395	2 -M16	200	68.0
879-825-18048816	450	450	488-542	488-516	514-542	642	705	307	399	2 -M16	200	86.2
879-825-20054016	500	500	540-594	540-568	566-594	694	760	307	403	2 -M16	200	106.0
879-825-24060616	600	600	606-660	606-634	632-660	760	825	307	409	2 -M16	200	138.0
879-825-24062416	600 o.s.	600	624-678	624-652	650-678	778	845	307	409	2 -M16	200	143.5

* See drawing on p. 3

HYMAX FLANGE ADAPTOR PN-10/16 NOMINAL SIZES 200-300mm

Krausz Part Number	DN (mm)	Flange PN-16 (mm)	Overall Range (mm)	Before removal of inner layer (mm)	After removal of inner layer (mm)	D (mm)	H (mm)	i (mm)	L (mm)	Bolts Qty. -Size	Torque (Nm)	Approx. Weight (kg)
878-825-08021716	200	200	217-250	217-233	232-250	328	355	101	163	1-M14	80	15
878-825-10027216	250	250	272-305	272-289	288-305	382	408	101	165	1-M14	80	21.5
878-825-12031516	300	300	315-347	315-331	330-347	422	445	101	169	1-M14	80	24.1

* See drawing on p. 3

PRODUCT TABLES

HYMAX FLANGE ADAPTOR PN-10/16 NOMINAL SIZES 350-600mm

Krausz Part Number	DN (mm)	Flange PN-16 (mm)	Overall Range (mm)	Before removal of inner layer (mm)	After removal of inner layer (mm)	D (mm)	H (mm)	i (mm)	L (mm)	Bolts Qty. -Size	Torque (Nm)	Approx. Weight (kg)
878-825-14037016	350	350	370-424	370-398	396-424	520	573	307	390	2-M16	200	51.5
878-825-16042016	400	400	420-474	420-448	446-474	580	640	307	390	2-M16	200	64
878-825-16044416	400	400	444-498	444-472	470-498	600	660	332	415	2-M16	200	66.5
878-825-20047016	450	500	470-524	470-498	496-524	625	685	206	295	2-M16	200	74.5
	500											
878-825-20052016	500	500	520-574	520-548	546-574	675	735	307	400	2-M16	200	86.5
	550											
878-825-24057216	500	600	572-626	572-600	598-626	725	785	206	300	2-M16	200	96
	550											
878-825-24062416	600 o.s	600	624-678	624-652	650-678	778	845	307	405	2-M16	200	141.5

* See drawing on p. 3

HYMAX FLANGE ADAPTOR BSTD NOMINAL SIZES 50-300mm

Krausz Part Number	DN (mm)	Flange PN-16 (mm)	Overall Range (mm)	Before removal of inner layer (mm)	After removal of inner layer (mm)	D (mm)	H (mm)	i (mm)	L (mm)	Bolts Qty. -Size	Torque (Nm)	Approx. Weight (kg)
870-825-02005412	50	50	54-77	54-66	65-77	133	165	95	146	1-M12	60	3.7
870-825-03008812	80	80	88-108	88-99	98-108	170	200	73	126	1-M12	60	4.6
870-825-04010812	100	100	108-143	108-126	125-143	220	250	73	130	1-M14	80	6.9
870-825-06013012	125	150	130-162	130-146	145-162	240	270	101	155	1-M14	80	9.3
870-825-06015812	150	150	158-190	158-174	173-190	270	295	101	155	1-M14	80	10.5
870-825-06016312	150 o.s	150	163-195	163-179	178-195	273	298	101	155	1-M14	80	10.5
870-825-08019012	175	200	190-222	190-206	205-222	298	325	101	155	1-M14	80	12.7
870-825-08021712	200	200	217-250	217-233	232-250	328	355	101	155	1-M14	80	13.2
870-825-10027212	250	250	272-305	272-289	288-305	382	408	101	155	1-M14	80	17.1
870-825-10027812	250 o.s	250	278-311	278-295	294-311	388	415	101	155	1-M14	80	17.2
870-825-12027212	250	300	272-305	272-289	288-305	382	408	103	162	1-M14	80	21
870-825-12031512	300	300	315-347	315-331	330-347	422	445	101	160	1-M14	80	21.5
870-825-12033412	300 o.s	300	334-366	334-350	349-366	440	465	101	160	1-M14	80	21.6

* See drawing on p. 3

HYMAX FLANGE ADAPTOR BSTD NOMINAL SIZES 350-600mm

Krausz Part Number	DN (mm)	Flange PN-16 (mm)	Overall Range (mm)	Before removal of inner layer (mm)	After removal of inner layer (mm)	D (mm)	H (mm)	i (mm)	L (mm)	Bolts Qty. -Size	Torque (Nm)	Approx. Weight (kg)
870-825-14037812	350	350	378-434	378-408	406-434	534	600	307	380	2-M16	200	53.4
870-825-16043412	400	400	434-488	434-462	460-488	588	655	307	380	2-M16	200	59.7
870-825-18048812	450	450	488-542	488-516	514-542	642	705	307	385	2-M16	200	71
870-825-20054012	500	500	540-594	540-568	566-594	694	760	307	390	2-M16	200	83.3
870-825-24060612	600	600	606-660	606-634	632-660	760	825	307	395	2-M16	200	106
870-825-24062412	600 o.s	600	624-678	624-652	650-678	778	845	307	395	2-M16	200	107

* See drawing on p. 3

Copyright © 2017 Krausz Industries Ltd., All rights reserved