

 50mm - 300mm  
 Flip gasket

 40mm, 350mm - 1,500mm  
 Detachable gasket

# HYMAX® COUPLING\*

## (40mm - 1500mm)

### PRODUCT SPECIFICATIONS

#### FEATURES

- GAME-CHANGING WIDE-RANGE COUPLING, PROVEN IN MILLIONS OF INSTALLATIONS WORLDWIDE
- SUITABLE FOR ALL PIPES - DUCTILE IRON, CAST IRON, STEEL, PE, PVC, AC, GRP
- PATENTED PROGRESSIVE PRESSURE-ASSISTED GASKET WITH 2-STAGE SEALING
- LIGHTWEIGHT CONSTRUCTION ENABLES FAST AND EASY INSTALLATION
- ALLOWS 4° DYNAMIC DEFLECTION ON EACH END, REDUCING FUTURE PIPE DAMAGE
- ONE PRODUCT CAN CONNECT PIPES OF TWO DIFFERENT MATERIALS
- T-HANDLE FOR EASIER LIFTING AND SLIDING OVER THE PIPE (EXISTS IN SIZES 75MM-300MM ONLY)

#### SPECIFICATIONS (\*\*)

##### STANDARDS

ALL PRODUCTS MEET OR EXCEED STANDARDS NSF-61 AND NSF-372.  
 PRODUCTS UP TO DN 300 WERE APPROVED BY 3RD PARTY ILAC LAB ACCORDING TO EN 14525.

##### SIZE

AVAILABLE IN NOMINAL DIAMETER SIZES 40mm - 1500mm.

##### MATERIALS

###### END RINGS

40mm - 300mm: S235JR GRADE STEEL, IN ACCORDANCE WITH EN 10025-2 (DIN 17100).  
 350mm - 400mm: S235JR GRADE STEEL, IN ACCORDANCE WITH EN 10025-2 (DIN 17100).  
 (OR DUCTILE IRON CASTING ASTM A536 GRADE 60-40-18).  
 450mm - 1500mm: S235JR GRADE STEEL, IN ACCORDANCE WITH EN 10025-2 (DIN 17100).

###### CENTER RING

40mm - 300mm: P235 GRADE STEEL, IN ACCORDANCE WITH EN 10217-1.  
 350mm - 1500mm: S235JR GRADE STEEL, IN ACCORDANCE WITH EN 10025-2 (DIN 17100).

###### GASKET

EPDM COMPOUNDED FOR WATER AND SEWERAGE. MEETS INTERNATIONAL STANDARDS FOR CONTACT WITH DRINKING WATER: NSF-61, KTW-UBA Elastomer guideline, W270, XP P 41-250, AS/NZS 4020, AND BS 6920. MEETS DIN EN 681-1 FOR WATER AND DRAINAGE APPLICATIONS.

###### BRIDGE

AISI 304 STAINLESS STEEL.

###### SPHERICAL SPACERS

AISI 304L STAINLESS STEEL.

###### COATING

100% FUSION BONDED EPOXY FOR ENHANCED CORROSION PROTECTION. AVERAGE THICKNESS 250 MICRON. MEETS NSF-61, BS 6920, ONORM B 5014-1, XP P 41-250, AS/NZS 4020, AND UBA-COATINGS GUIDELINE.

###### NUTS AND BOLTS

AISI 304 STAINLESS STEEL. ROLLED THREAD AND ANTI-GALLING COATING.

\* The product is protected by various patents registered in various countries.

\*\* For details about Made to Order (MTO) products please contact your KRAUSZ distributor.

## PRODUCT PERFORMANCE

<b>WORKING TEMPERATURE</b>	<b>EPDM GASKET</b>		<b>EPOXY COATING</b>	
	CONTINUOUS OPERATION   -30°C UP TO +85°C SHORT TIME OPERATION   -30°C UP TO +100°C		ABOVE GROUND APPLICATIONS   UP TO +50°C BELOW GROUND APPLICATIONS   UP TO +65°C	
<b>DYNAMIC DEFLECTION</b>	<b>UP TO 4° PER SIDE</b>			
<b>MIN. PIPE INSERTION</b>	<b>40mm - 300mm</b>	<b>350mm - 1200mm</b>	<b>1200mm - 1500mm</b>	
	55mm	100mm	150mm	
<b>MAXIMUM OFFSET FOR MISALIGNED PIPES</b>	<b>40mm - 80mm</b>	<b>100mm - 1500mm</b>		
	10mm	13mm		
<b>MAXIMUM OUT OF ROUNDNESS</b>	<b>40mm</b>	<b>50mm - 80mm</b>	<b>100mm - 300mm</b>	<b>350mm - 1500mm</b>
	2mm	5mm	8mm	13mm
<b>WORKING PRESSURE</b>	<b>40mm - 600mm</b>	<b>650mm - 1500mm</b>		
	16 BAR	SEE TABLE BELOW FOR DETAILS		
<b>RATED PRESSURE</b>	<b>1.5 X WORKING PRESSURE</b>			
<b>VACUUM TEST</b>	<b>0.8 BAR</b>			

## PRODUCT TABLES

### HYMAX Coupling 40-300

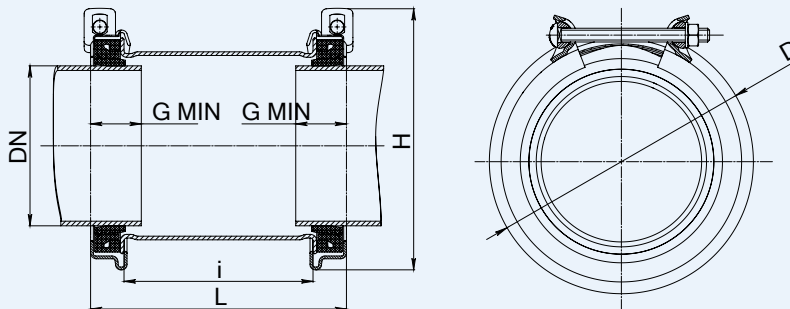

### HYMAX COUPLING NOMINAL SIZE 40mm (\*)

Krausz Part Number	DN (mm)	Overall Range (mm)	Before Removal of Inner Layer (mm)	After Removal of Inner Layer (mm)	D (mm)	H (mm)	i (mm)	L (mm)	Bolts Qty. -Size	Torque (Nm)	Approx. Weight (kg)
860-825-0041-16	40	41-54	41-50.5	50-54	100	130	100	156	2 -M12	45	2.6

\* Detachable gasket

## HYMAX2 COUPLING NOMINAL SIZES 50-300mm (\*)

Krausz Part Number	DN (mm)	Overall Range (mm)	Range in Closed Gasket Position (mm)	Range in Open Gasket Position (mm)	D (mm)	H (mm)	i (mm)	L (mm)	Bolts Qty. -Size	Torque (Nm)	Approx. Weight (kg)
860-826-0054-16	50	54-77	54-66	65-77	133	165	100	172	2 -M12	70	3.4
860-826-0088-16	80	88-108	88-99	98-108	170	200	150	222	2 -M12	70	4.9
860-826-0108-16	100	108-143	108-126	125-143	220	250	150	223	2 -M14	80	6.0
860-826-0130-16	125	130-162	130-146	145-162	240	270	205	275	2 -M14	80	7.6
860-826-0158-16	150	158-190	158-174	173-190	270	295	205	275	2 -M14	80	9.3
860-826-0163-16	150 o.s.	163-195	163-179	178-195	273	298	205	275	2 -M14	80	9.3
860-826-0190-16	175	190-222	190-206	205-222	298	325	205	275	2 -M14	80	11.5
860-826-0217-16	200	217-250	217-233	232-250	328	355	205	275	2 -M14	80	11.7
860-826-0272-16	250	272-305	272-289	288-305	382	408	205	275	2 -M14	100	12.7
860-826-0278-16	250 o.s.	278-311	278-295	294-311	388	415	205	275	2 -M14	100	12.7
860-826-0315-16	300	315-347	315-331	330-347	422	445	205	275	2 -M14	110	14.0
860-826-0334-16	300 o.s.	334-366	334-350	349-366	440	465	205	275	2 -M14	110	17.5

\* Flip gasket

## PRODUCT TABLES

### HYMAX Coupling 350-600

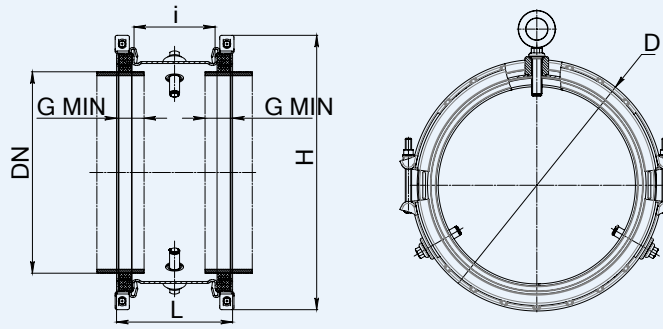

#### HYMAX COUPLING NOMINAL SIZES 350-600mm (\*)

Krausz Part Number	DN (mm)	Overall Range (mm)	Before Removal of Inner Layer (mm)	After Removal of Inner Layer (mm)	D (mm)	H (mm)	i (mm)	L (mm)	Bolts Qty. -Size	Torque (Nm)	Approx. Weight (kg)
860-825-0375-16P	350	375-431	375-405	403-431	534	600	205	295	4 -M16	200	35.5
860-825-0378-16P	350 400	378-434	378-408	406-434	534	600	205	295	4 -M16	200	35.5
860-825-0434-16P	400	434-488	434-462	460-488	588	655	205	295	4 -M16	200	40.0
860-825-0488-16P	450 500	488-542	488-516	514-542	642	705	205	295	4 -M16	200	43.0
860-825-0540-16P	500 550	540-594	540-568	566-594	694	760	205	295	4 -M16	200	46.0
860-825-0606-16P	600	606-660	606-634	632-660	760	825	205	295	4 -M16	200	52.0
860-825-0624-16P	600	624-678	624-652	650-678	778	845	205	295	4 -M16	200	52.0

\* Detachable gasket

#### HYMAX COUPLING NOMINAL SIZES 650-1500mm (\*)

DN - 650 up to 1500 mm with range of 54 mm	DN (mm)	Bolts Qty. -Size	Torque (Nm)	Working Pressure (bar)	Rated Pressure (bar)
	650-900	4-1"NCx350	300	12	18
	900-1000	4-1"NCx350	400	12	18
	1000-1300	4-1"NCx350	400	10	15
	1300-1350	4-1"NCx350	450	10	15
	1350-1500	4-1"NCx350	450	8	12

\* Contact your KRAUSZ distributor for more details.